

# アングル用金具

ANGLE BRACKETS

JK-1~7

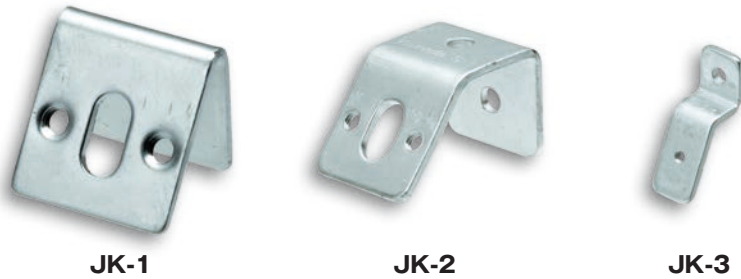

JK-1

JK-2

JK-3

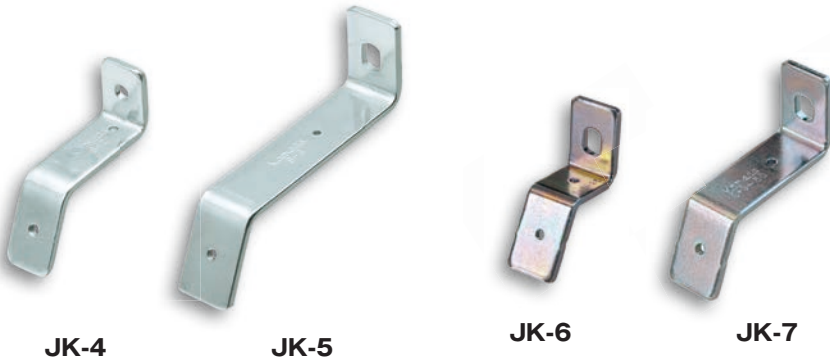

JK-4

JK-5

JK-6

JK-7

**特 徴** ●端子の取付けに条件があっても多様に対応できます。  
**Feature** ●端子取り付けの金具としてご利用ください。取り付けも簡易です。

●Can be used diversely even if there is a condition to the attachment of the terminal.  
 ●Please use as a bracket of terminal mounting. Mounting is also simple.

**材 質** ●鉄 (SPCC)

**表面処理** ●クロメートめっき

**用 途** ●端子取り付け金具

**備 考** ●市販品につき、ケース単位 (入数) でのご注文をお願い致します。

**Material** ●Cold rolled steel plate (SPCC)

**Finish** ●Zinc chromate plating

**Specific Use** ●Terminal mounting bracket

**Remarks** ●Please order in case unit (Quantity) about products on the market.

品番 Product No.	M	W	自重 (g) Weight	入数 Lot	単価 Price
JK-1	5		20	50	¥130
JK-1-4	4		20	50	¥130
JK-2	5	8.5	38	10	¥125
JK-2-4	4	7	38	10	¥105
JK-3			16.4	50	¥110
JK-4			29.4	10	¥115
JK-5			55.8	10	¥125
JK-6			459	10	¥140
JK-7			50	10	¥160

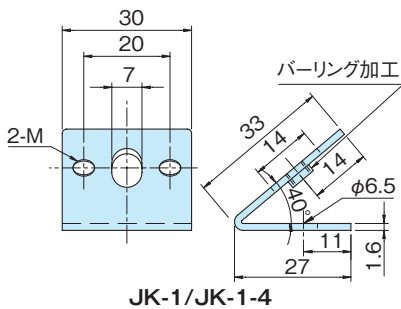

JK-1/JK-1-4

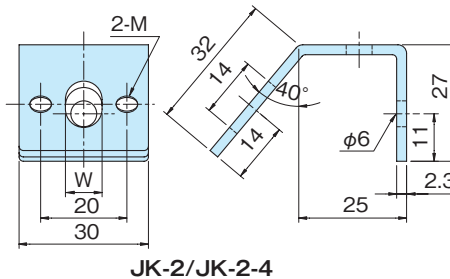

JK-2/JK-2-4

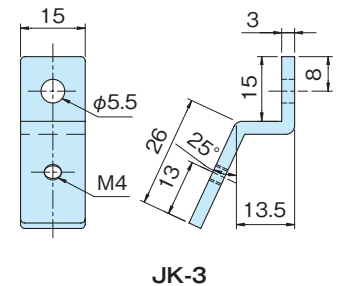

JK-3

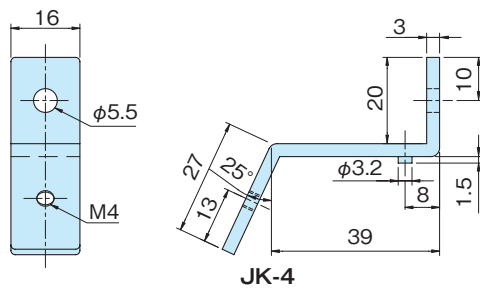

JK-4

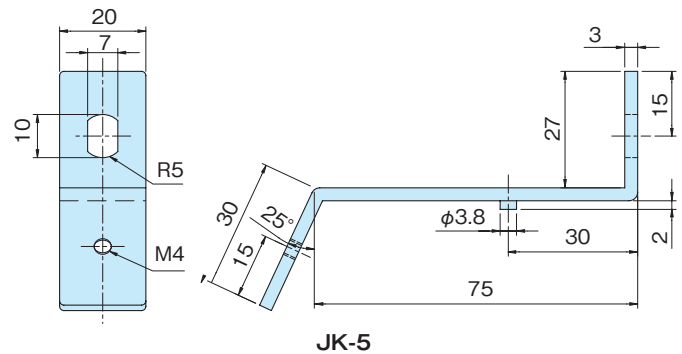

JK-5

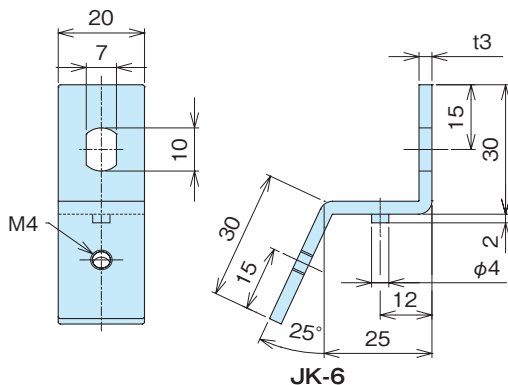

JK-6

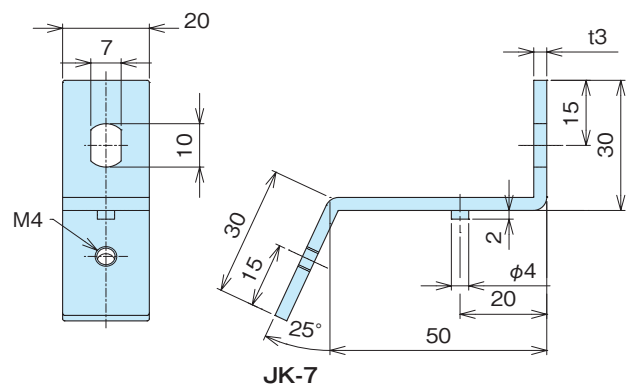

JK-7