

# 強力マグネットキャッチ

MAGNETIC CATCHES

## DMC-10

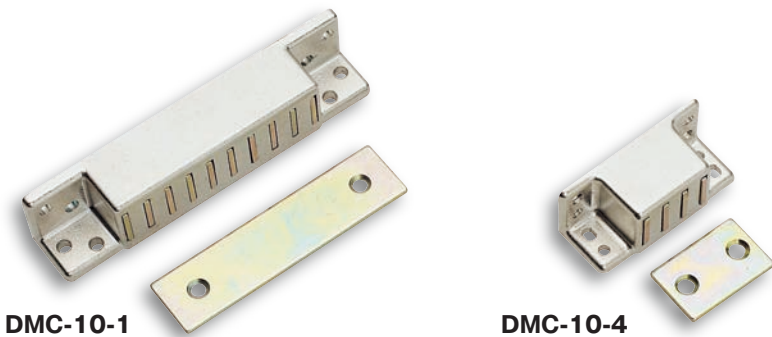

- 材質** ●マグネット/Ba-フェライト(異方性)  
ケース/亜鉛合金(ZDC)  
受板/鉄(SPCC)
- 表面処理** ●ケース/ニッケルめっき(MZNi)  
受板/クロメートめっき
- 用途** ●配分電盤・工作機械
- Material** ●Magnet/Ba-ferrite (anisotropy)  
Case/Zinc alloy (ZDC)  
Catch plate/Cold rolled steel plate (SPCC)
- Finish** ●Case/Nickel plating (MZNi)  
Catch plate/Zinc chromate plating
- Specific Use** ●Distribution boards, machine tools

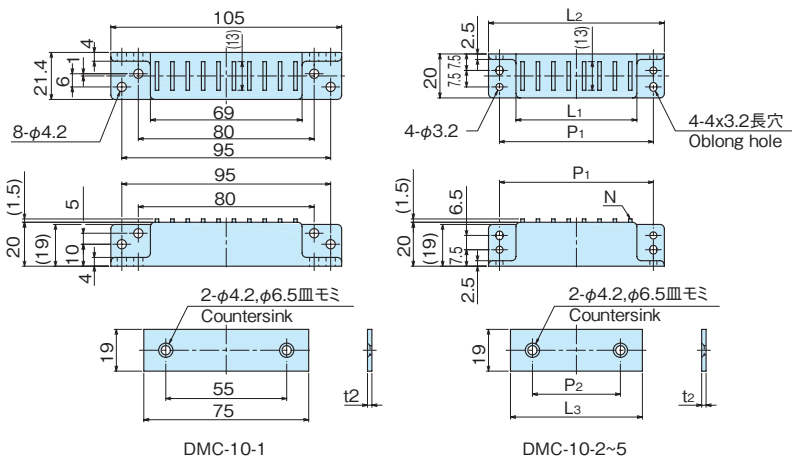

品番 Product No.	L <sub>1</sub>	L <sub>2</sub>	L <sub>3</sub>	P <sub>1</sub>	P <sub>2</sub>	N	吸着力 (kgf)	自重(g) Weight	単価 Price
DMC-10-1	左図参照						15	206	¥1,200
DMC-10-2	55	80	60	70	40	8	14	140	¥1,100
DMC-10-3	41	61	43	50	27	6	11	110	¥900
DMC-10-4	27	50	29	40	18	4	7	74	¥750
DMC-10-5	20	40	22	30	12	3	3	56	¥590

# マグネットキャッチ

MAGNETIC CATCHES

## DMC-11

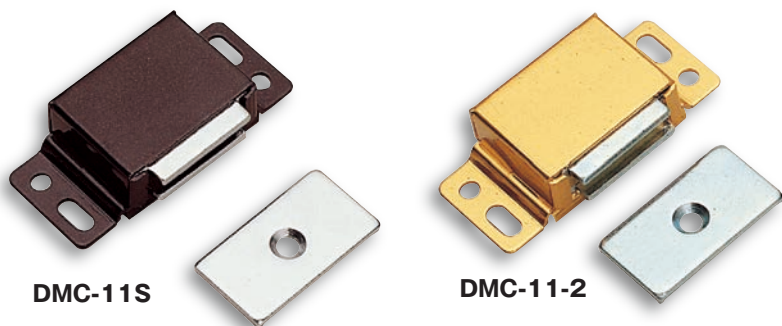

- 材質** ●マグネット/フェライト  
ケース/アルミニウム  
受板/鉄(SPCC)
- 表面処理** ●受板/DMC-11-2:三価ユニクロめっき  
DMC-11S:クロムめっき
- 用途** ●計測機器・分電盤
- 備考** ●市販品につき、ケース単位(入数)でのご注文をお願い致します。
- Material** ●Magnet/Ferrite  
Body/Aluminum  
Catch plate/Cold rolled steel plate (SPCC)
- Finish** ●Catch plate/DMC-11-2:Unichrome plating  
DMC-11S:Chrome plating
- Specific Use** ●Measuring equipments, Distribution board
- Remarks** ●Please order in case unit (Quantity) about products on the market.

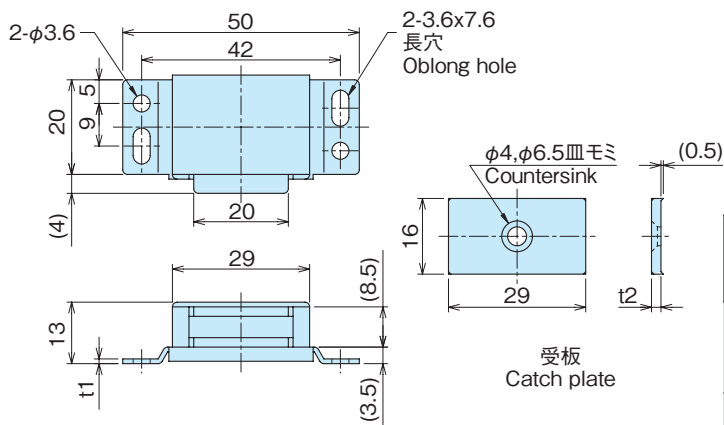

品番 Product No.	本体(ケース) Main body(Case) 仕上 Finish	吸着力 (kgf) Adsorption	自重(g) Weight	入数 Lot	単価 Price
DMC-11-2	金色 アルマイト Alumite treatment (Gold)	3.0	37	40	¥190
DMC-11S	茶メタリック塗装 Metallic finish (Brown)	5.5	37	40	¥230