

分岐回路接続銅帯

CONNECTING BARS FOR BRANCH CIRCUIT



EF-D



EF-D

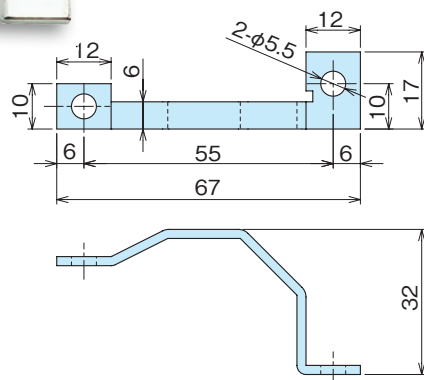

材 質 ●銅板 (Cu)・2t
表面処理 ●ニッケルめっきと光沢スズめっきがありますので御指定ください。

Material ●Copper (Cu)
Finish ●Please specify the nickel plating or gloss tinning.

品番 Product No.	自重(g) Weight	入数 Lot	単価 Price
EF-D	11.6	100	¥220

■参考取付例

Example of installing reference

単相 100V

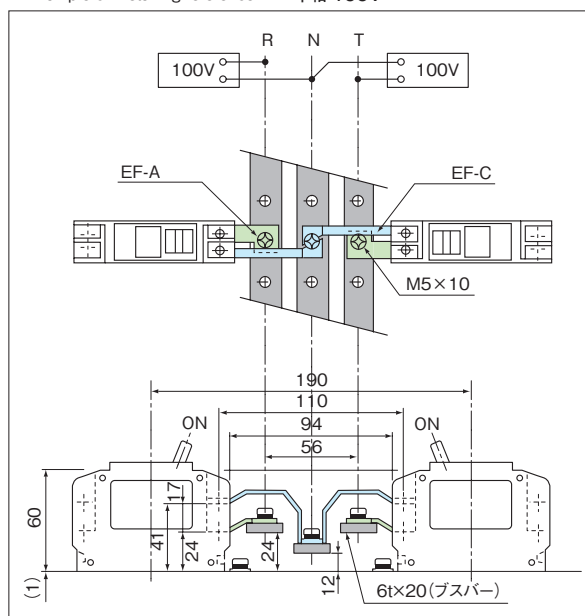

単相 100Vと200V

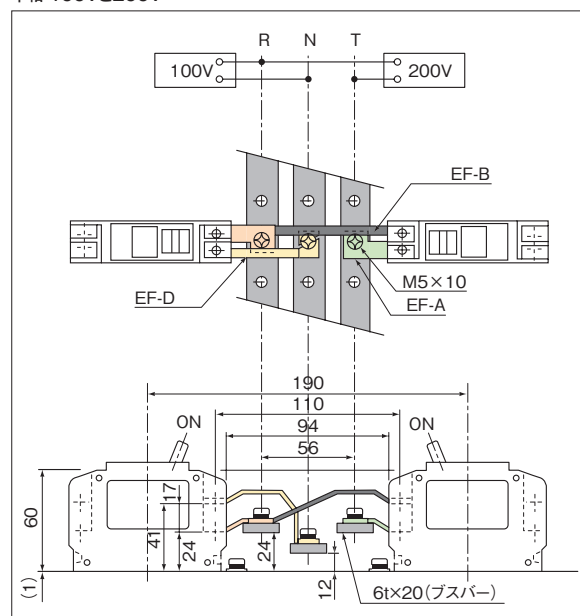

単相 200V

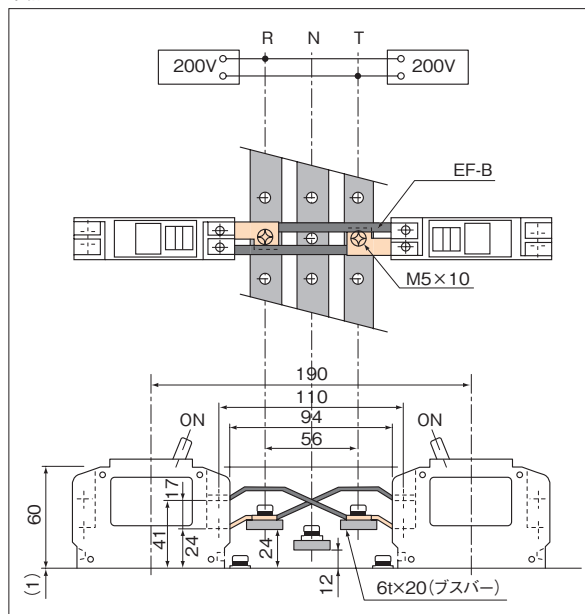

■接続例

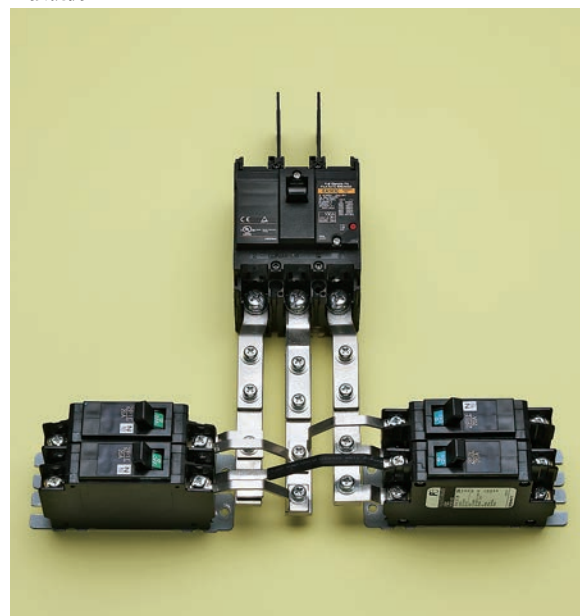
主幹バー
分岐バー